

Intermediate Frequency Circuit Components for Integration of on-Chip Amplifier with THz Detectors

Rahul Yadav ^(1,2), Sascha Preu ⁽²⁾ and Andreas Penirschke ⁽¹⁾

(1) Technische Hochschule Mittelhessen, Friedberg (Hessen), Germany,
 (2) Technische Universität Darmstadt, Germany



12th INTERNATIONAL BEAM INSTRUMENTATION CONFERENCE
 SASKATOON, CANADA
 September 10-14, 2023



TECHNISCHE UNIVERSITÄT DARMSTADT

Direct THz Detectors

Thermal Detectors

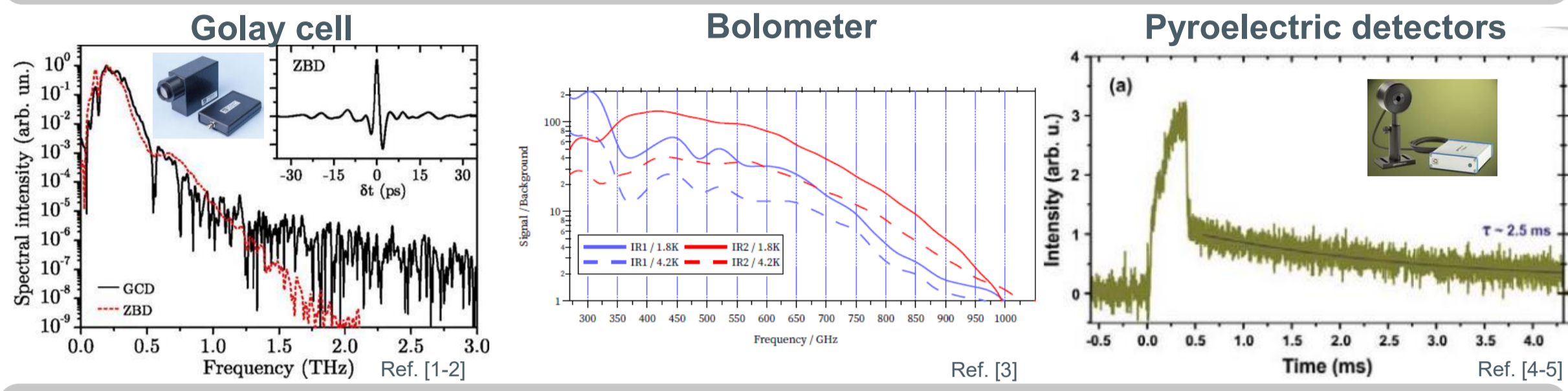

Rectifying Detectors

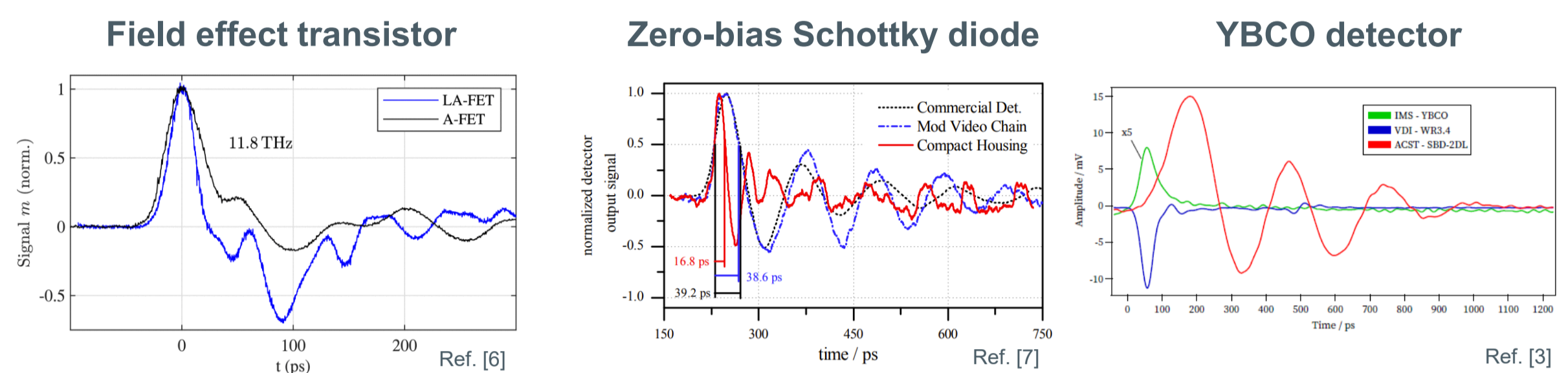
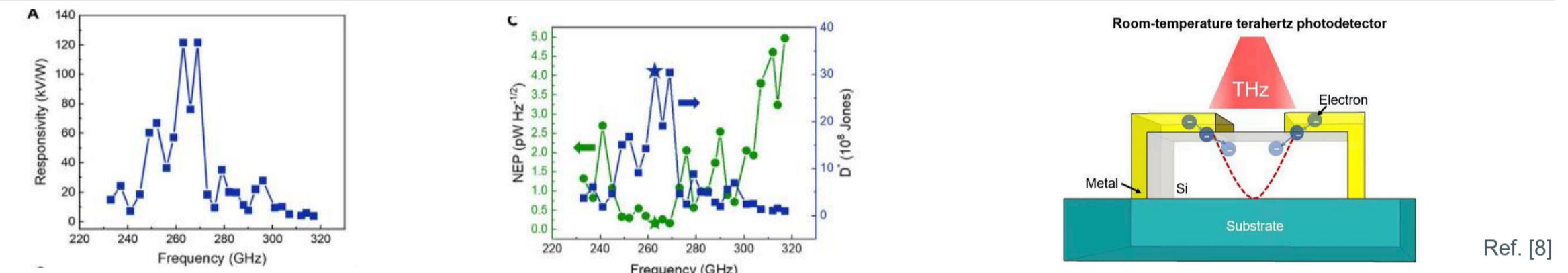
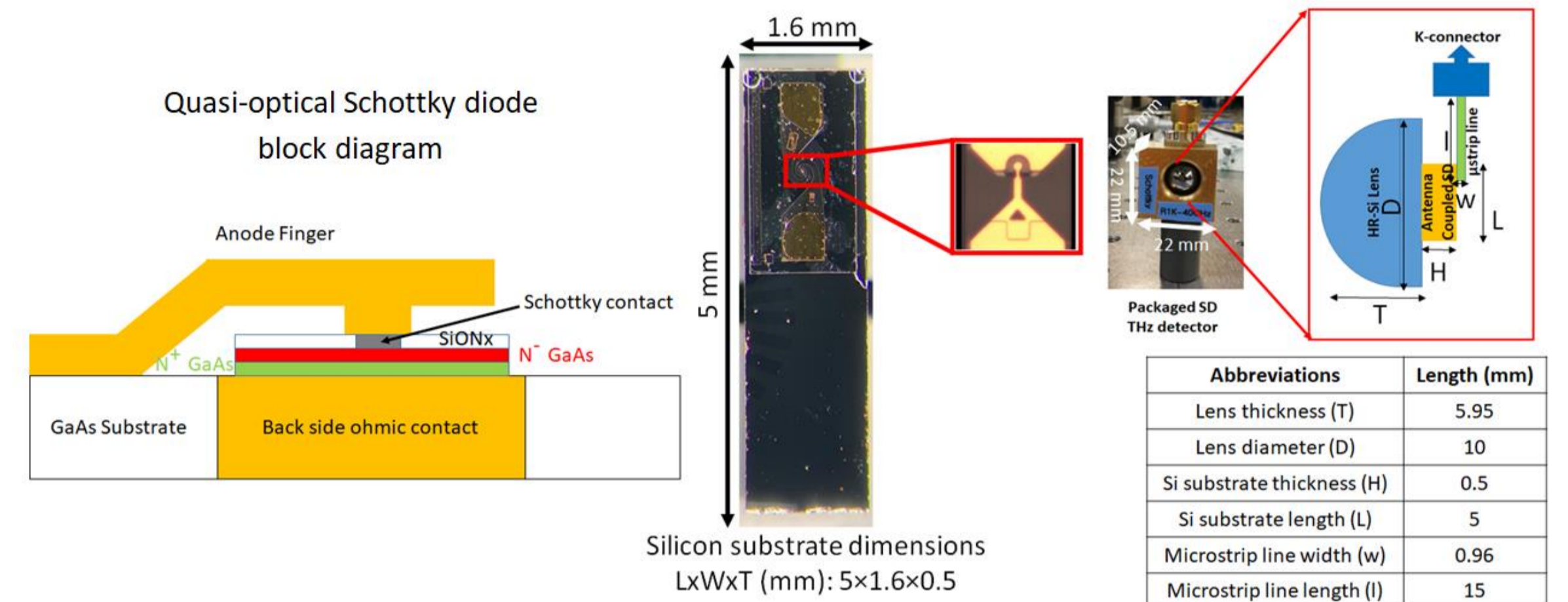

Photo Detectors



Block Diagram of THz Detector

Version 1



Version 2

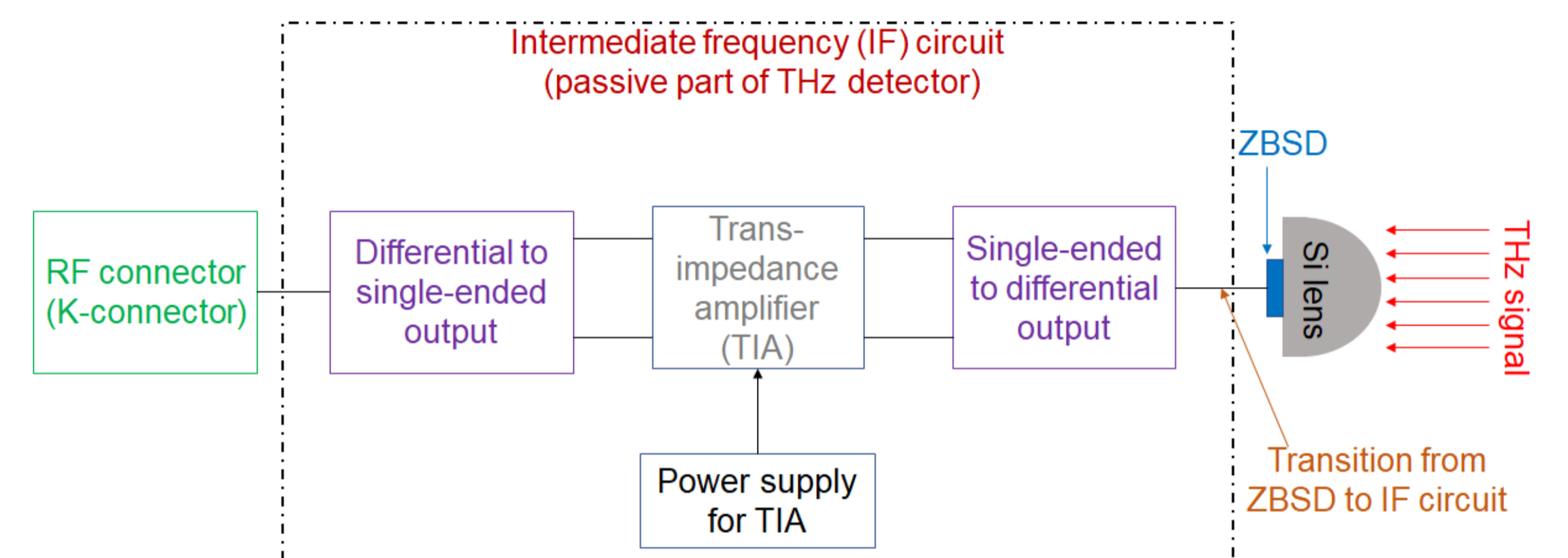

Simulation Studies on Transition to IF CKT

Investigated transition structures:

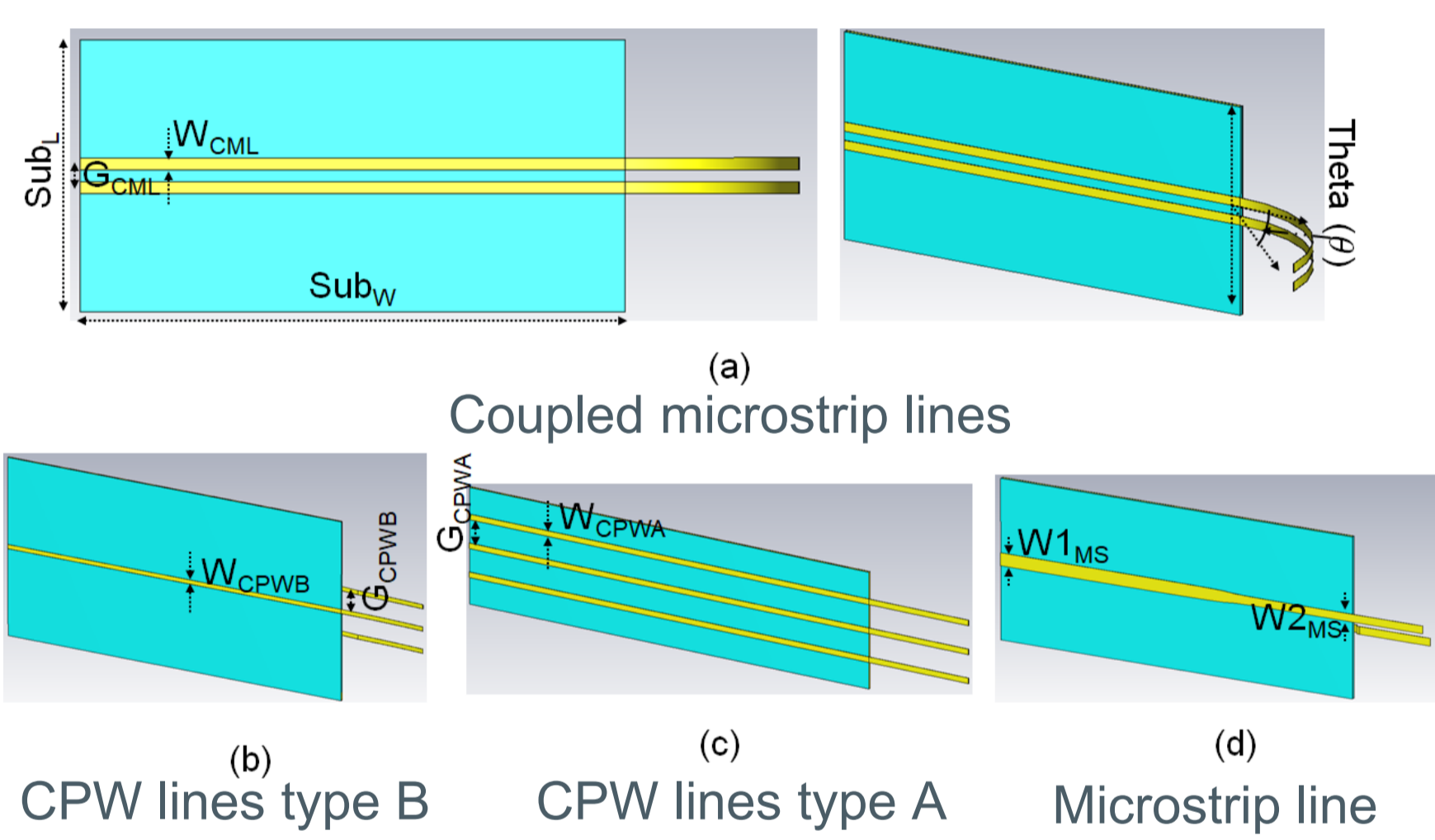

Parameter	Values (mm)
Sub _L	0.25
Sub _W	1
G _{CML}	0.011
W _{CML}	0.011
G _{CPWB}	0.050
W _{CPWB}	0.012
G _{CPWA}	0.050
W _{CPWA}	0.012
W _{1MS}	0.020
W _{2MS}	0.012

Investigation on coupled microstrip lines transition when varying bending angle (θ):

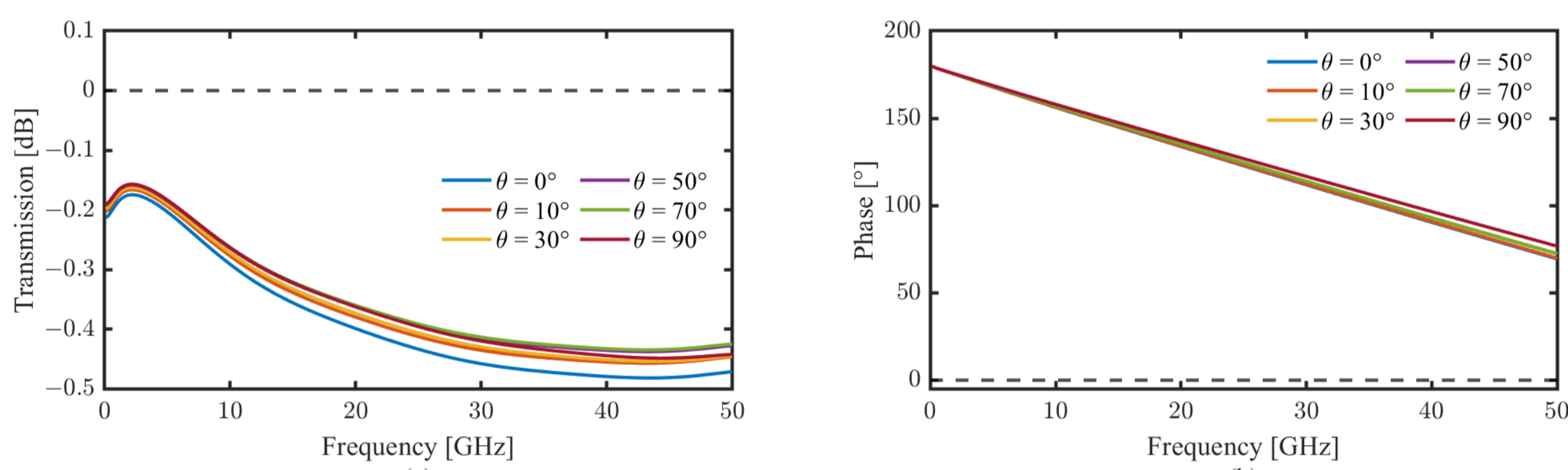

Comparison of different types of transition when bending angle (θ) is 0°:

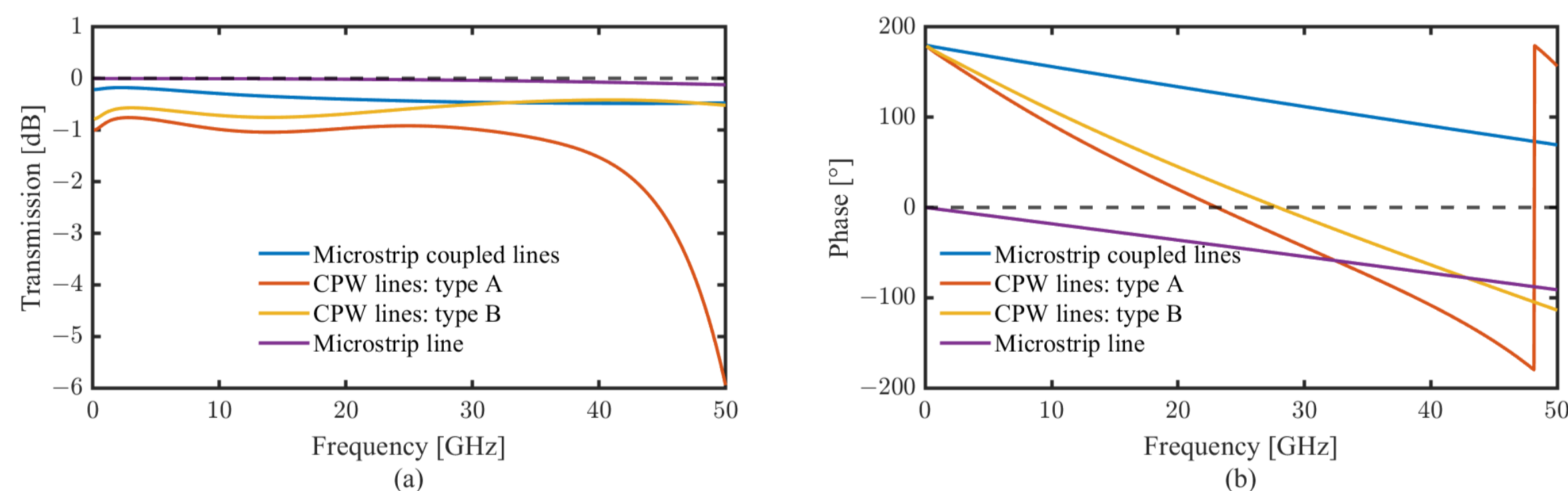

Simulation Studies on Broadband Planar Power Divider

Investigation on ultra broadband planar power divider (UBPPD): Multi-section UBPPD analysis:

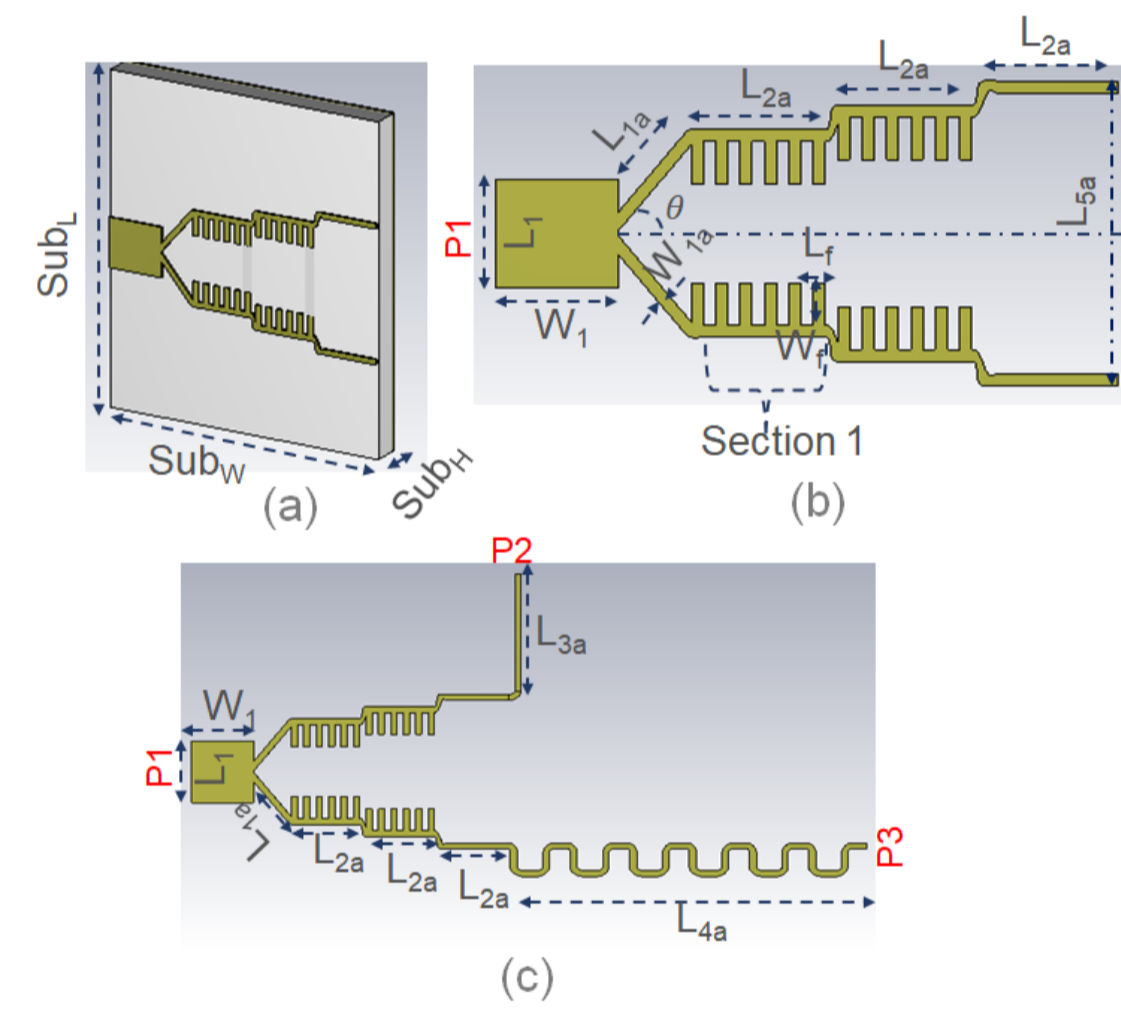

Parameter	Values (mm)
Sub _L	3
Sub _W	2.5
Sub _H	0.25
L ₁	0.45
L _{1a}	0.44
L _{2a}	0.57
W ₁	0.50
W _{1a}	0.060
W _r	0.18
L _r	0.05
L _{3a}	0.95
L _{4a}	2.9
L _{5a}	1.26

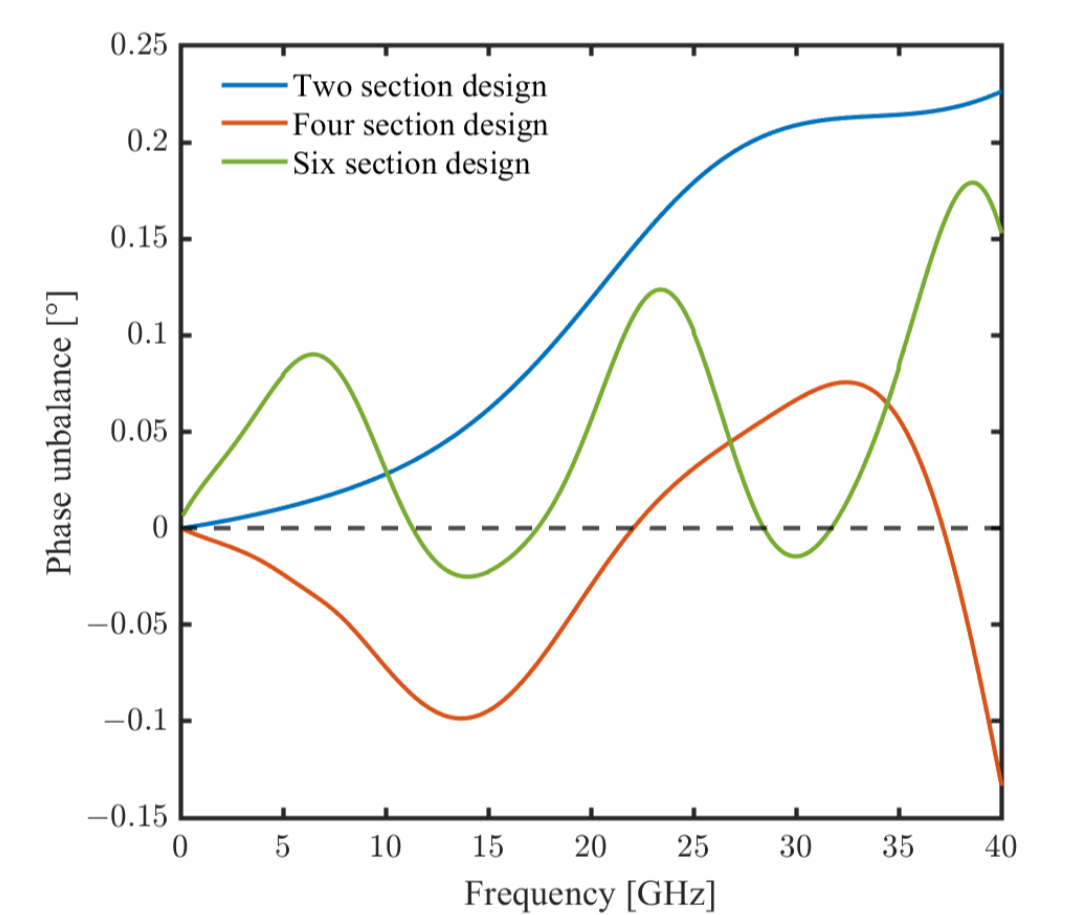

(a) Sketch of UBPPD
 (b) 2 section sketch of UBPPD
 (c) 2 section UBPPD with phase shifter

Effect of varying theta (θ) on UBPPD performance:

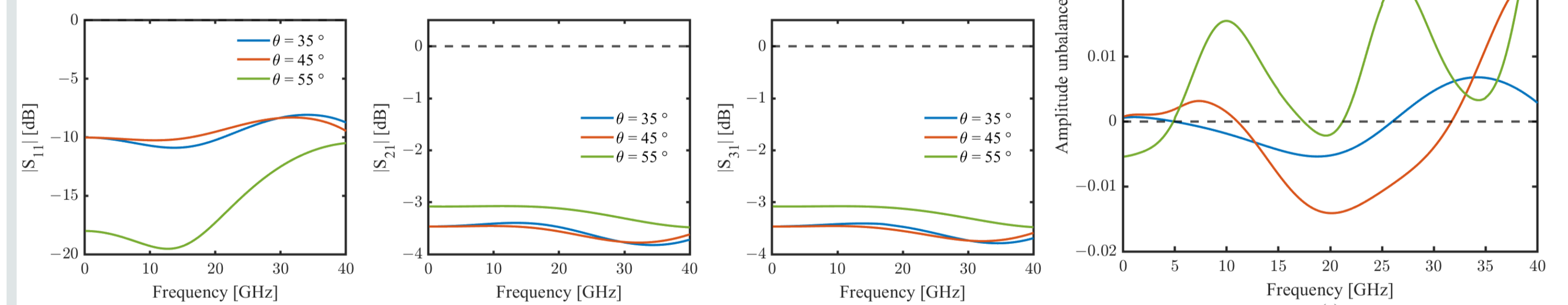

Conclusions and Outlook

- Broadband & narrowband direct THz detectors
- Investigation on IF CKT components
- Fast and sensitive THz detectors
- Ultra-broadband integrated IF circuit with THz detector

Please attend WE1C03 talk on 13th Sept 2023 at 10:00 am

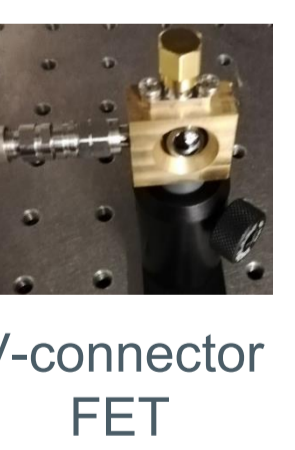

References



Related Work



Acknowledgement



Bundesministerium für Bildung und Forschung

Contract no.: 05K22R01

TUP010

Poster Session II (16:00 – 17:30)

Rahul Yadav, M.Sc

rahul.yadav@iem.thm.de

