

# DESIGN AND STUDY OF CAVITY QUADRUPOLE MOMENT AND ENERGY SPREAD MONITOR\*

Q. Wang, Q.Y. Dong, L.T. Huang

Dalian Institute of Chemical Physics, Chinese Academy of Sciences, Dalian, China

Q. Luo<sup>†</sup>

NSRL, University of Science and Technology of China, Hefei, China

## Abstract

A nondestructive method to measure beam energy spread using the quadrupole modes within a microwave cavity is proposed. Compared with a button beam position monitor (BBPM) or a stripline beam position monitor (SBPM), the cavity monitor is a narrow band pickup and therefore has better signal-to-noise ratio (SNR) and resolution. In this study, a rectangular cavity monitor is designed. TM<sub>220</sub> mode operating at 4.76 GHz in the cavity reflects the quadrupole moment of the beam. The cavity plans to be installed behind a bending magnet in Dalian Coherent Light Source (DCLS), an extreme ultraviolet FEL facility. In this position, the beam has a larger dispersion, which is beneficial to measure the energy spread. A quadrupole magnet, a fluorescent screen, and a SBPM with eight electrodes is installed near the cavity for calibration and comparison. The systematic framework and simulation results are also discussed in this paper.

## INTRODUCTION

Energy spread is an important parameter that reflects the quality of the beam. Especially in linear accelerators used as storage rings and collider injectors, ensuring a good energy spread of the beam can improve injection efficiency and maintain beam stability. Therefore, real-time and high-resolution measurement of energy spread needs to be achieved.

The most widely used method for energy spread measurement at present is to insert a fluorescent screen or an OTR after bending magnets. By measuring the generated light spot, the transverse distribution of the beam can be determined, and the energy spread is capable to be obtained based on the principle that different energy electrons have different turning radius [1]. However, this intercepting method is unsuitable for real-time measurement or feedback control. Therefore, a nonintercepting energy spread monitor is required.

A feasible nondestructive method is using stripline beam position monitor (SBPM) [2–4]. SBPM is installed at positions with high value of dispersion function, allowing extraction of the beam's quadrupole moment to obtain the energy spread. The sensitivity of this method is influenced by the angle of electrodes.

\* Work supported by the National Key Research and Development Program of China No.2022YFA1602201, the International Partnership Program of the Chinese Academy of Sciences Grant No. 211134KYSB20200057 and the STCF Key Technology Research Project.

<sup>†</sup> email address: luoqueing@ustc.edu.cn

In order to achieve the energy spread measurement with high-resolution, this paper proposes the method of RF resonant cavity. Similar to SBPMs, cavities can also measure the quadrupole moment, thus obtaining the energy spread. Compared to SBPMs, cavities have higher signal-to-noise ratio (SNR), enabling better quadrupole moment resolution, which can also be confirmed in the position measurement. Additionally, in the direction of the beam, cavities can realize a more compact layout.

This paper introduces a design of cavity-based quadrupole moment and energy spread monitor for the Dalian Coherent Light Source (DCLS), an extreme ultra-violet FEL facility with a length of 100 m, and provides simulation results to verify the feasibility of the proposed approach.

## THEORETICAL BASIS

While passing through the cavity, the bunch will excite different eigenmodes. The signal amplitude of an eigenmode can be written as

$$V = k_n q \int_{-T}^T f(t) \exp(i\omega t) dt, \quad (1)$$

where  $q$  is bunch charge, the final integral is related to the longitudinal distribution of the bunch, and  $k_n$  is the loss factor, which is related to the mode type. As shown in Fig. 1, for a rectangular cavity rotated 45° about the axis, its TM<sub>220</sub> mode amplitude is proportional to the beam quadrupole moment [5, 6].

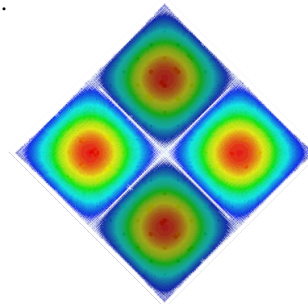

Figure 1: Electric field of TM<sub>220</sub> mode in rectangular cavity. Warmer colors represent stronger electric fields.

$$V_{TM220} \propto x^2 - y^2 + \sigma_x^2 - \sigma_y^2, \quad (2)$$

where  $x$  and  $y$  are the beam positions in the two directions.  $\sigma_x$  and  $\sigma_y$  are the beam rms sizes in the two directions. When the bunch length is short and does not change significantly, the quadrupole moment  $x^2 - y^2 + \sigma_x^2 - \sigma_y^2$  can be obtained by extracting the charge and the amplitude of the TM<sub>220</sub> mode.

Assuming that the vertical dispersion,  $\eta_y$ , is zero, the relationship between energy spread and quadrupole moment can be written as

$$\sigma_x^2 - \sigma_y^2 = \beta_x \epsilon_x + \left(\eta_y \frac{\Delta E}{E}\right)^2 - \beta_y \epsilon_y + g, \quad (3)$$

where  $\beta_x$  and  $\beta_y$  are  $\beta$  functions,  $\eta_x$  is the horizontal dispersion,  $\epsilon_x$  is the horizontal emittance, and  $g$  is the correction factor, which can be determined by calibration. The two directions  $x$  and  $y$  are interchangeable. Therefore, after excluding the influence of the beam position, the relationship between the TM220 amplitude and the energy spread can be established.

As indicated in Eq. (3), placing the monitor at a position with high value of dispersion function is beneficial to improve the sensitivity and resolution of the quadrupole moment measurement. For a linear accelerator, it is more suitable to place the monitor after the bending magnets.

## LAYOUT AND FRAMEWORK

The scheme for measuring beam energy spread using a cavity will be carried out in the undulator section of DCLS. The beam parameters in this section are shown in Table 1.

Table 1: Beam Parameters in the Undulator Section of DCLS

Parameter	Value
Beam energy	300 MeV
Charge	500 pC
Bunch length (rms)	~0.12 mm
Transverse dimension (rms)	~0.1 mm
$\beta$ function (mean)	6-29 m
Normalized emittance	1-2 mm · mrad

The cavity will be installed after the bending magnet at the end of the undulator section, as shown in Fig. 2. The dispersion at this position is significant, which is advantageous for energy spread measurement. A fluorescent screen is set downstream to get information of beam position and provide online calibration, and the upstream ICT on the bending magnet can synchronously provide absolute measurement of the beam charge. Additionally, an eight-electrode SBPM will be installed for energy spread measurement as a reference, which can also provide information of beam charge and beam position.

The systematic framework is shown in Fig. 3. When the beam passes through the cavity, the signal generated by the excited eigenmodes will be coupled out via feedthroughs. In order to overcome cable attenuation, the signal first enters an amplifier, then passes through long cables to the accelerator tunnel and connects to the analog front end for down conversion. Afterwards, it is fed into the electronics for amplitude extraction and energy spread calculation.

## PHYSICAL DESIGN

The TM220 mode of the rectangular cavity can indicate the magnitude of the quadrupole moment. In order to share

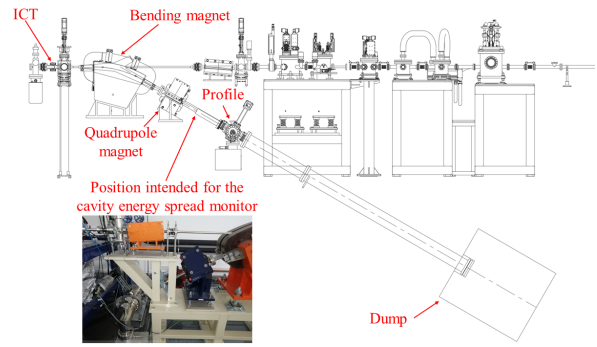

Figure 2: Layout diagram.

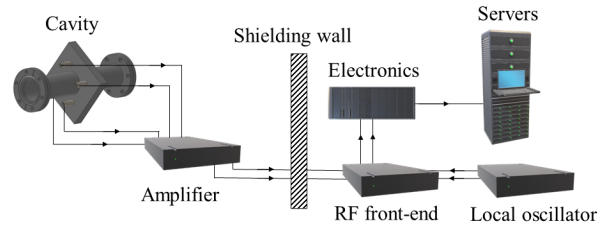

Figure 3: Systematic framework of the cavity quadrupole moment and energy spread monitor.

the analog front end with other cavity monitors on the DCLS, the operating frequency of the TM220 mode is set to be 4.76 GHz.

The relationship between the frequency of the TM<sub>m</sub><sub>n</sub> mode and the dimensions of the cavity can be expressed as

$$f_{TM220} = \frac{c}{2} \sqrt{\left(\frac{m}{a}\right)^2 + \left(\frac{n}{a}\right)^2}, \quad (4)$$

where  $c$  is speed of light in vacuum, and  $a$  represents the length of one side of the square cavity. By calculation, we have  $a = 89.1$  mm. In order to reduce the impact on beam, the longitudinal length  $l$  of the cavity is set to 10 mm.

The TM220 mode signal is coupled out by feedthroughs. The feedthroughs are set at the position with the strongest electric field of the TM220 mode, and are inserted along the electric field direction for optimal coupling. Four feedthroughs are used to maintain electric field symmetry. The inner conductors of the feedthroughs should not be inserted too deeply to avoid distorting the electric field.

The diameter of the beam pipe at the installation location is 35 mm. The cutoff frequency of it is 5.023 GHz, which ensures that the TM220 mode signal operating at 4.7 GHz does not leak out. The beam pipe will affect the frequencies of all eigenmodes inside the rectangular cavity.

When machining a rectangular cavity, the milling cutter cannot process the edge of the beam direction to 90°, so chamfering must be considered. A square groove is milled on a cubic metal plate to serve as the cavity. Due to the length of the cavity in the  $z$ -direction (beam direction) reaching 10 mm, a milling cutter with a blade length of 15 mm and a blade diameter of 6 mm is chosen to enter along the  $z$ -

direction for cutting the groove. This will leave chamfers with a radius of 3 mm at the four corners. This also affects the frequencies of the eigenmodes. Therefore, numerical calculations are needed to correct the cavity dimensions obtained from Eq. (4). CST Microwave Studio [7] is used for frequency simulation calculation. The final structure and dimensions of the cavity are determined as shown in Fig. 4 and Table 2.

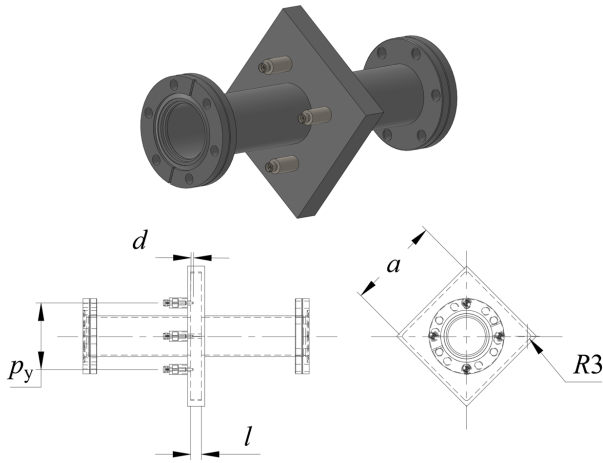

Figure 4: The structure of the rectangular cavity.

Table 2: Optimized Dimensions of the Cavity

Parameter	Value
$a$	86.2 mm
$l$	10 mm
$p_y$	61.8 mm
$d$	1.4 mm
Chamfer	R3

## SIMULATION

The cavity model is established in CST, and virtual beams are loaded for simulation. The beam simulation is divided into two cases. In the first case, the transverse sizes of the beam are zero ( $\sigma_x = 0, \sigma_y = 0$ ), and the beam position is changed. In the second case, the beam is located at the axis ( $x = 0, y = 0$ ), and the transverse sizes are varied. The time-domain and frequency-domain output signals of the cavity are shown in Fig. 5.

The results show that there is a good linear relationship between the amplitude of the TM220 mode and the quadrupole moments. The quadrupole moment sensitivity of the cavity monitor is better than  $0.03 \text{ mm}^2$  in the frequency domain. This parameter of the eight-electrode SBPM is generally only on the order of  $10^{-3}$ . The cavity monitor is more likely to achieve better measurement resolution.

The simulation results show that the TM220 mode is successfully excited when the quadrupole moment is present. The variations of quadrupole moments  $x^2 - y^2 + \sigma_x^2 - \sigma_y^2$  and the amplitude of TM220 modes obtained through simulation at different beam positions and beam transverse sizes are shown in Fig. 6.

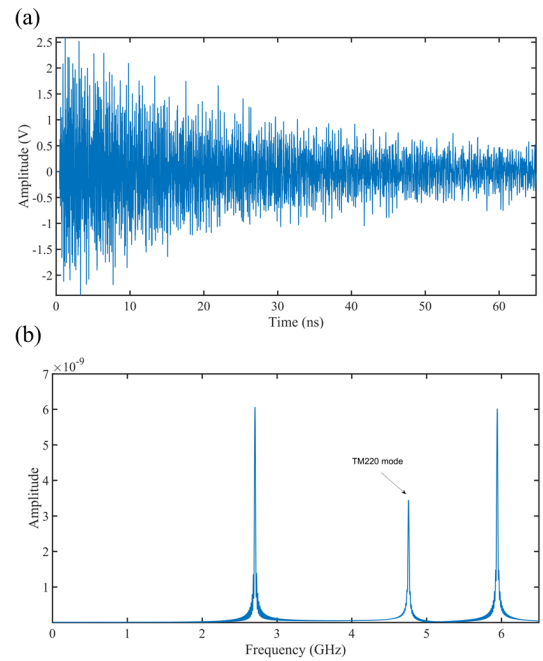

Figure 5: The output signal of the cavity when  $x = 10, y = 0, \sigma_x = 0$ , and  $\sigma_y = 0$ . (a) is the time-domain signal. (b) is the frequency-domain signal.

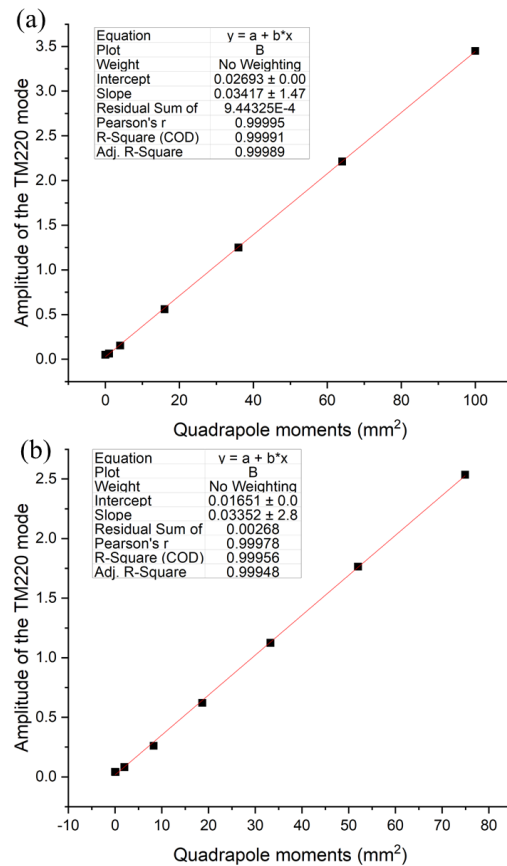

Figure 6: Variation of TM220 mode amplitude with beam quadrupole moment. (a) is  $x$  varying from 1 to 10 mm when  $\sigma_x = 0, \sigma_y = 0$ , and  $y = 0$ . (b) is  $\sigma_y$  varying from 0.03 to 8.66 mm when  $x = 0, y = 0$ , and  $\sigma_x = 1$  mm.

## SUMMARY

In this paper, the design of the cavity quadrupole moment and energy spread monitor is shown, and the simulation results indicate a good linear relationship between its TM220 mode output signal and the beam quadrupole moment. The beam experiment will be carried out at DCLS soon. This study provides a new approach for nondestructive and high-resolution measurement of beam energy spread.

## REFERENCES

- [1] M. Satoh, K. Furukawa, and T. Suwada, “Energy-spread-feedback system for the KEKB injector Linac”, in *Proc. PAC’05*, Knoxville, TN, USA, May 2005, paper RPAT088, pp. 4212–4214.
- [2] T. Suwada, M. Satoh, and K. Furukawa, “Nondestructive beam energy-spread monitor using multi-strip-line electrodes”, *Phys. Rev. ST Accel. Beams*, vol. 6, p. 032801, Mar. 2003.  
doi:10.1103/PhysRevSTAB.6.032801
- [3] J. C. Dooling, F. R. Brumwell, L. Donley, G. E. McMichael, and V. F. Stipp, “Beam analysis using the IPNS Linac ESEM”, in *Proc. LINAC’04*, Knoxville, Lübeck, Germany, Aug. 2004, paper TUP61, pp. 405–407.
- [4] J. Fang, P. Lu, Q. Luo, B. Sun, and X. H. Wang, “Analysis and calculation of beam energy spread monitor for HLS LINAC”, in *Proc. IPAC’10*, Kyoto, Japan, May 2010, paper MOPE028, pp. 1029–1031.
- [5] D. Whitum and Y. Kolomensky, “Analysis of an asymmetric resonant cavity as a beam monitor”, *Rev. Sci. Instrum.*, vol. 70, no. 5, p. 2300, May 1999.  
doi:10.1103/P10.1063/1.1149756
- [6] Q. Luo *et al.*, “New beam diagnostics and related study on HLS photo-injector and HLS II”, in *Proc. IPAC’14*, Dresden, Germany, Jun. 2014, pp. 3578–3580.  
doi:10.18429/JACoW-IPAC2014-THPME140
- [7] CST, <https://www.3ds.com/>